

**Revolabs Fusion™ System
Tabletop Dialer**

User Guide



Rev 1.10



Table of Contents

Product Description	3
Tabletop Dialer Front Panel	4
Tabletop Dialer Key Functions	6
Installing the Batteries	7
Placing a Telephone Call	8
Adding Speed Dial Numbers	8
Editing Speed Dial Numbers	9
Deleting Speed Dial Numbers	9
Adjusting Far End Volume	9
Tabletop Dialer Settings	
Setting Display Backlight Time	10
Setting Screen Contrast	10
Display Signal Quality	10
Display Battery Level	10
Tabletop Dialer Configuration	
Set Password	11
Display RF Address	11
Display Firmware Version	11
Pairing The Tabletop Dialer to Fusion	12
Resetting the RF Address	12
Powering Down the Tabletop Dialer	13
Resetting the Password	13
Safety and Regulatory Information	14
Specifications	14
Warranty	15

Product Description

Use the Tabletop Dialer to dial and manage the conference phone numbers for the Revolabs Fusion™ Wireless Microphone System.

RF remote control with touch pad and digital display with stored memory for quick dialing.

Part Numbers Covered in This Document:

Revolabs Part Number: 07-TTDIAL-01

Features

- Backlit 2 line LCD Screen
- Caller ID
- Call/hang-up buttons
- Volume Control for Fusion
- Previous Number Redial
- Microphone Mute
- Mute/Call Indicator Light
- Flash Button
- Non-skid feet

Menu Features

- Edit/Store phone numbers
- Speed-dial numbers

Tabletop Dialer Front Keypad

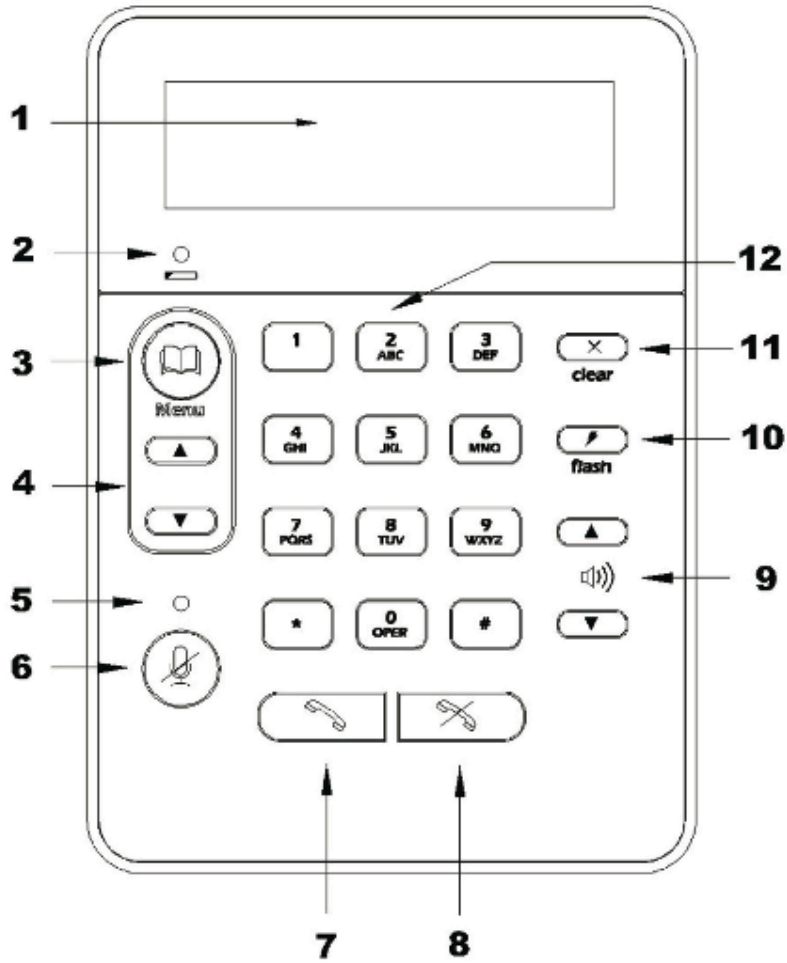

Tabletop Dialer Front Keypad (cont.)

Fusion Front Panel

The Revolabs Tabletop Dialer provides convenient dial control and management of conference phone numbers of the Fusion™ Wireless Microphone System.

1. 2 Line LCD Display
2. Low Battery Indicator
3. Menu Button
4. Up/Down Scroll Buttons
5. Mute/Call Status Indicator
6. Mute Button
7. Off Hook Button Dial/Re-Dial
8. On Hook Button (End Call)
9. Volume Up / Down Buttons
10. Flash Button
11. Clear Button
12. Alpha Numeric Keypad

Tabletop Dialer Keypad Functions

Low Battery Indicator LED

The Low Battery LED will flash red when the batteries need to be replaced

Menu Buttons

Used to scroll through menu options

Mute/Call Status Indicator LED

The Mute/Call LED will flash red for muted and green for un-muted when on an active call

Mute Button

Used to mute/un-mute all microphones

Dial/Re-Dial (Off Hook & Call Answer)

Used to answer or initiate a call

End Call (On Hook)

Used to end a call

Volume

Increase and decrease the volume

Flash

Used to initiate flash functions such as three way calling if phone system supports them

Clear

Used to delete input entries or to exit menu functions

Installing Batteries

1. Remove the bottom stand/battery cover by gently depressing the spring latch with your finger and tilting the cover away from the catch on the Dialer.
2. Next insert 4 AA Batteries, ensuring to correctly place the polarity of the batteries as indicated in each battery slot.
3. Re-install the stand/battery cover by placing the bottom tabs into the slots on the Dialer and gently ensuring the spring latch catches.

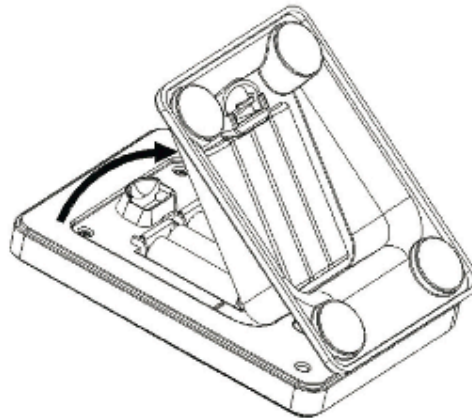
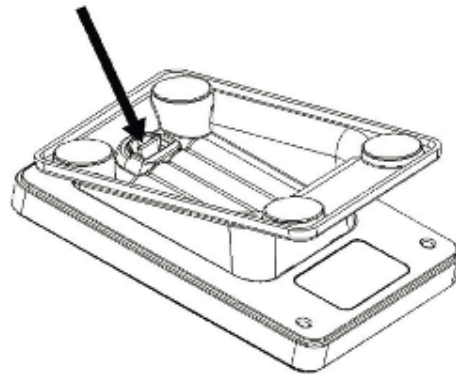

Placing a Telephone Call

There are 4 options for placing a call using the Tabletop Dialer.

1. Enter the phone number you want to dial and then press the Dial button
2. Speed-Dial by pressing a single number that represents one of the stored phonebook entry number (0-9) and then pressing the Dial button
3. Press the Down scroll button continuously until you get to the Speed-Dial entry you want to dial and then press the Dial button
4. Press the Dial button (wait for dial tone) then enter the number you wish to dial. (best option if your phone system requires a pause after dialing 9 to get an outside line)

Adding Speed-Dial numbers

1. Press the Menu button to bring up the *Main menu* and press the Menu button again at the *Speeddial* option
2. At the *Add* option screen, press the menu button again and use the Scroll Down button to navigate to the empty key number you wish to use for Speed-Dialing this entry, then press the Menu button again
3. At the *Entry Name* screen use the key pad to enter the name for this entry. Both lowercase and capital letters are available by continuing to press the numeric key. For instance pressing the number 2 key continuously you will scroll through a,b,c,2,A,B,C then back to a. Once you have finished entering the name, press the Menu button again
4. At the *Entry Number* Menu enter the number you wish to associate with this speed-dial number. Note: If your phone system requires a numeric key entry such as dialing 9 for an outside line, don't forget to add it.
5. Finally press the Menu button once the number is complete and you will get a message "Entry Stored"



Editing Speed-Dial numbers

1. Press the Menu button to bring up the *Main menu* and press the Menu button again at the *Speeddial* option
 2. Press the Down scroll button to the *Edit* option and press the Menu button
 3. Use the scroll buttons to get to the number you wish to edit and press the Menu button
 4. At the *Entry Name* screen use the clear button to delete characters and the Keypad to edit the name.
 5. When done, press the Menu button and you will get a message “Entry Stored”
-

Deleting Speed-Dial numbers

1. Press the Menu button to bring up the *Main menu* and press the Menu button again at the *Speeddial* option
 2. Press the Down scroll button to the *Delete* option and press the Menu button
 3. Use the scroll button till you get to the number you want to delete then press the Menu button and you will get a message “Entry Deleted”
-

Adjusting Volume

Use the Volume Up/Down buttons to increase and decrease the volume from Telephone, VTC and Aux inputs sources.

Note: This adjustment controls the far end volume levels of the Room output only.

Setting Display Backlight Time

1. Press the Menu button to bring up the *Main menu* and press the down scroll button to select *Settings* and press the Menu button
 2. Press the Menu button again at *Backlight Time* and use the scroll buttons to select between *Off*, *Short (3 seconds)* and *Long (7 seconds)* and press the Menu button
-

Setting Display Contrast

1. Press the Menu button to bring up the *Main menu* and press the down scroll button to select *Settings* and press the Menu button
 2. Scroll down to *Set Contrast* and press the Menu Button
 3. Use the scroll buttons to adjust the contrast
-

Display RF Signal Strength

1. Press the Menu button to bring up the *Main menu* and press the down scroll button to select *Settings* and press the Menu button
 2. Scroll down to *Signal Quality* and press the Menu Button
-

Display Battery Level

1. Press the Menu button to bring up the *Main menu* and press the down scroll button to select *Settings* and press the Menu button
2. Scroll down to *Battery Level* and press the Menu Button

Setting a Password for Administrative Control

1. Press the Menu button to bring up the *Main menu* and press the down scroll button to select *Configuration* and press the Menu button
2. At the *Set Password* option press the Menu button.
3. Use the key pad to enter a password.
4. Once you have finished entering the password, press the Menu button again

Displaying Tabletop Dialer RF Address

1. Press the Menu button to bring up the *Main menu* and press the down scroll button to select *Configuration* and press the Menu button
2. Enter your password if prompted and press the Menu button
3. Scroll down to *RF Address* and press the Menu Button

Note: Used for troubleshooting when there is more than one Tabletop Dialer

Displaying Software Version

1. Press the Menu button to bring up the *Main menu* and press the down scroll button to select *Configuration* and press the Menu button
2. Enter your password if prompted and press the Menu button
3. Scroll down to *Code Version* and press the Menu Button

Pairing the Tabletop Dialer to Fusion

1. Press the Menu button to bring up the *Main menu* and press the down scroll button to select *Configuration* and press the Menu button
2. Enter your password if prompted and press the Menu button
3. Scroll down to *Pairing* and press the Menu Button
4. Place the Dialer within 2' (60cm) of the Fusion base and press the Menu button (followed by confirmation *Pairing Succeeded* or *Already Paired to Base*)

Note: If the Dialer is already paired to a Fusion System, the RF address must be reset first before it can be paired to another Fusion System.

Resetting the RF Address

1. Press the Menu button to bring up the *Main menu* and press the down scroll button to select *Configuration* and press the Menu button
2. Enter your password if prompted and press the Menu button
3. Scroll down to *Reset RF Address* and press the Menu Button

Powering Down the Tabletop Dialer

1. Hold down the End Call button until *Powering Down* is displayed (about 3 seconds).
 2. The Dialer will then completely shut down until you press any key to restart it.
-

Resetting the Password

1. Power down the Dialer by holding down the End Call button. (about 3 seconds)
 2. Then press and hold the Menu button while the Dialer displays "*Revolabs Fusion*". Release the Menu button and the Dialer will display "*Password Reset*".
-

Code Download

Do not use unless instructed by Revolabs.

Specifications

Dimensions, (L, W, H) and Weight:

4.75" (12.07 cm) x 6.75" (17.15 cm) x 2.75" (6.99 cm)
0.94 lb (0.42 kg)

Radio Frequency:

07-TTDIAL-01 2.4 GHz

Power Requirements:

4 AA Batteries

Battery Life: Up to 6 months

Range: Up to 50' (15 meters) Line of site, no obstructions

Environmental Requirements

40-100 degrees F (5-40 C)
20-85% Humidity

This device complies with Part 15 of the FCC Rules. Operation is subject to the following two conditions: (1) this device may not cause harmful interference, and (2) this device must accept any interference received, including interference that may cause undesired operation.

Changes or modifications not expressly approved by Revolabs could void the user's authority to operate the equipment.

Warranty

Revolabs, Inc. warrants this product to be free of manufacturing defects. Repair or replacement of any defective part or unit (at the discretion of the Seller) will be free of charge for the period of one year.

Any attempt by the user to alter the equipment, or equipment damaged by negligence, accident, or Acts of God voids this warranty.

The Seller shall not be liable for any consequential damage resulting from the malfunction of this product. Should the user experience unsatisfactory performance from this equipment, contact the Seller to obtain instructions for return, or replacement, as deemed necessary.

This warranty is not transferable by the original end user.

Revolabs, Inc.
63 Great Road
Maynard, MA 01754
www.revolabs.com
800.326.1200
support@revolabs.com



© 2008 REVOLABS, INC. All rights reserved. No part of this document may be reproduced in any form or by any means without express written permission from Revolabs, Inc. Product specifications are subject to change without notice.

Part #2950065-00 REV 1.10

