

Installation and Operation Guide

Revolabs Solo™ Single Channel Wireless Microphone System Models 02-DSKSYS, 04-DSKSYSEU

© 2007 REVOLABS, INC. All rights reserved. No part of this document may be reproduced in any form or by any means without express written permission from Revolabs, Inc. Product specifications are subject to change without notice.

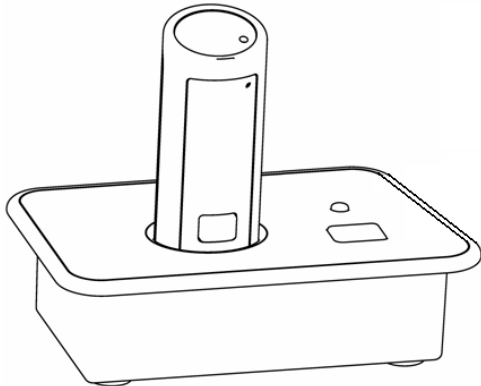

Revolabs, Inc.



Revolabs Solo™ Single Channel
02-DSKMAN-PAP-11
December 2007 (Rev 3.1)

Table of Contents

| | |
|--|----|
| Safety and General Information..... | 1 |
| Introduction | 4 |
| System Components | 5 |
| Revolabs Solo™ Single Channel Charger Base | 5 |
| Mute Button | 6 |
| Power Module | 6 |
| USB Connection..... | 6 |
| External Audio Connection..... | 6 |
| Installing the Solo Single Channel System..... | 6 |
| Computer Software Set-up..... | 7 |
| Revolabs Solo™ Wireless Microphones | 12 |
| Using with Wearable Wireless Microphone..... | 12 |
| Using with TableTop Microphone..... | 14 |
| Using with XLR Microphone Wireless Adapter | 15 |
| Using with a Solo Executive Multi-channel System | 18 |
| Charging the Batteries..... | 18 |
| When to Charge | 18 |
| Setting the Broadcast Power Level | 19 |
| Pairing the Microphone to the Charger Base | 20 |
| LED Status Indications | 22 |
| Warranty | 23 |
| Solo Single Channel Specifications..... | 24 |

Safety and General Information

This section contains important information regarding safe and efficient system operation, and declarations of *required* certification / regulation compliance. Please read this information prior to using your Revolabs system.

FCC User Information and Notice

FCC Registration Number: 0014898290

FCC ID Number: T5V02DSKSYS Revolabs Charger

FCC ID Number: T5V01EXEMIC Revolabs Microphone

Users are not permitted to make changes or modify the equipment in any way. Changes or modifications not expressly approved by Revolabs, Inc. could void the user's authority to operate the equipment.

This device complies with Part 15 of the FCC Rules. Operation is subject to the following two conditions: (1) this device may not cause harmful interference, and (2) this device must accept any interference received, including interference that may cause *undesired* operation.

Federal Communications Commission (FCC) Radiation Exposure Statement

Important: This equipment complies with FCC radiation exposure limits set forth for an uncontrolled environment.

Industry Canada Notice to Users

Operation is subject to the following two conditions: (1) This device may not cause interference and (2) This device must accept any interference, including interference that may cause *undesired* operation of the device Ref IC: RSS 210 Sec. 5.11. The term "IC:" before the certification / registration number signifies that registration was performed based on a Declaration of Conformity indicating that Industry Canada technical specifications were met. It does not imply Industry Canada approval of the equipment. See Ref IC Self-Marking 6(f) and RSP-100 Sec. 4.

IC ID Number: 6455A-02DSKSYS Revolabs Solo™ Desktop Charger

IC ID Number: 6455A-01EXEMIC Revolabs Solo™ Microphone

Restricted use with certain medical devices

Hearing Aids

Some devices may interfere with some hearing aids. In the event of such interference, you may want to consult with your hearing aid manufacturer to discuss alternatives.

Other Medical Devices

If you use any other personal medical device, consult the manufacturer of your device to determine if it is adequately shielded from RF energy. Your physician may be able to assist you in obtaining this information.

Export Law Assurances

This product is controlled under the export regulations of the United States of America and Canada. The Governments of the United States of America and Canada may restrict the exportation or re-exportation of this product to certain destinations.

For further information contact the U.S. Department of Commerce or the Canadian Department of Foreign Affairs and International Trade. The use of wireless devices and their accessories may be prohibited or restricted in certain areas. Obey the laws and regulations on the use of these products.

02-DSKSYS North America UPCS Usage Restriction

Due to the UPCS frequencies used, this product is licensed for operation only in the United States of America and Canada.

04-DSKSYSEU European Union Usage Restriction

Due to the frequencies used, this product is licensed for operation only in the European Union countries.

European Compliance

This equipment has been approved in accordance with Council Directive 1999/5/EC "Radio Equipment and telecommunications Equipment."



Conformity of the Equipment with the guidelines below is attested by the CE mark.

Model Numbers:

04-DSKSYSEU-BLK-11 Revolabs Charger

03-EXEMICEU-BLK-11 Revolabs Executive Microphone

05-TBLMICEU-OM-BLK-11 Revolabs Solo™ Table Microphone Omni

05-TBLMICEU-DR-BLK-11 Revolabs Solo™ Table Microphone Cardioid

Standards to which Conformity is declared:

RF ETSI EN 301 406 V 1.4.1 03/2001

EMC ETSI EN 301 489-6 v1.2.1 (2002-04)

WEEE Notification:

The Waste Electrical and Electronic Equipment (WEEE) directive (2002/96/EC) is intended to promote recycling of electrical and electronic equipment and their components at end of life.



2003/11/EC & 2002/95/EC "RoHS Compliance Directive":

The products referenced herein are in compliance with the EU directive 2003/11/EC and EU directive 2002/95/EC.

Introduction

Congratulations on the purchase of your Revolabs Solo™ Single Channel wireless microphone system! This wireless system provides high band-width audio from a compact wireless microphone enabling reliable, secure, and untethered personal communication.

The Single Channel Wireless Microphone System is a unique marriage of innovative technology and ergonomic stylish design, featuring 1.9 GHz DECT technology. This product enhances audio communication in both personal and enterprise applications, using Multi-Carrier, Time Division Multiple Access and Time Division Duplex (MC/TDMA/TDD) radio transmissions both to and from the microphone.

This means that the system can co-exist with other wireless products such as wireless LANs (802.11 b&g) and cellular phones.

Note: *It is recommended that no more than 3 Single Channel Systems, nor a Single Channel and Multichannel System, be used in the same room to avoid interference.*

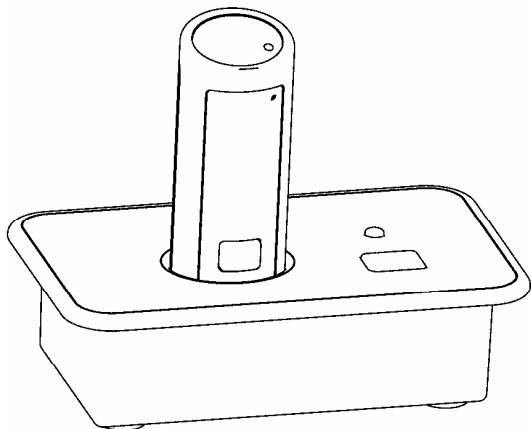

System Components

Your Revolabs Solo™ Single Channel System package contains:

- Compact Charger Base
- Solo Wireless Microphone (varies)
- Power Module
- External Audio Cable
- USB cable
- Installation and Operation Guide
- Solo Single Channel *Quick Start* Guide

Revolabs Solo™ Single Channel Charger Base

Use the Charger Base to store and charge the Microphone when not in use. The Microphone must be properly inserted into the base and seated flush for charging to occur.

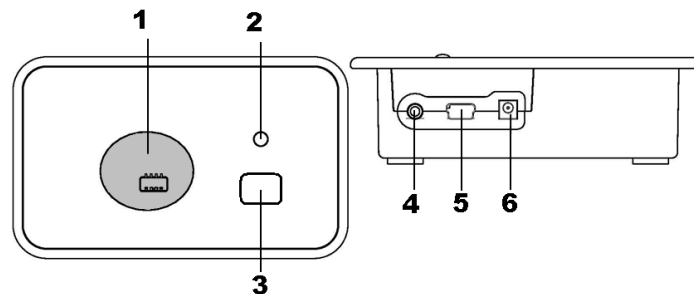

1. **Charger Bay** — charges Microphone
2. **LED indicator** — mute and pairing status indicator
3. **MUTE button** — duplicates the Microphone mute function
4. **AUDIO port** — 2.5mm analog in/out external audio connection
5. **Mini USB connector** — computer audio connection
6. **POWER connector** — power supply input

Mute Button

Pressing the **MUTE** button toggles between muting (flashing RED LED status) and un-muting (flashing GREEN LED status) on the Wireless Microphone.

Note: Press the **MUTE** button on a Microphone will similarly toggle between mute and un-mute and display on both status LEDs.

Power Module

The Charger Base requires 5VDC power. Plug the supplied AC adapter into a convenient 110-240VAC, 50-60Hz power outlet and the adapter into the power connector.

USB Connection

Use the supplied cable to connect the mini USB connector to the Charger Base and the standard end to your computer USB port.

External Audio Connection

The Single Channel System includes a cable for connecting the Charger Base to an external audio or conferencing system. The provided 2.5mm miniplug-to-RCA cable allows the microphone's unbalanced line level audio to be used with a mixer or conferencing system using the RCA male jack. Output from the mixer or conferencing system can be connected to the RCA female plug providing audio to the microphone's earpiece. An optional Line-to-mic level cable (07-STEMIC-PPP) is available for purchase.

Installing the Solo Single Channel System

The Revolabs Solo™ Single Channel system is easily installed into either the office or conference room environment. Simply plug the power supply into a convenient outlet and attach the USB cable to a computer or laptop, or connect the 2.5mm audio cables to an audio system. Power is not provided by the USB cable.

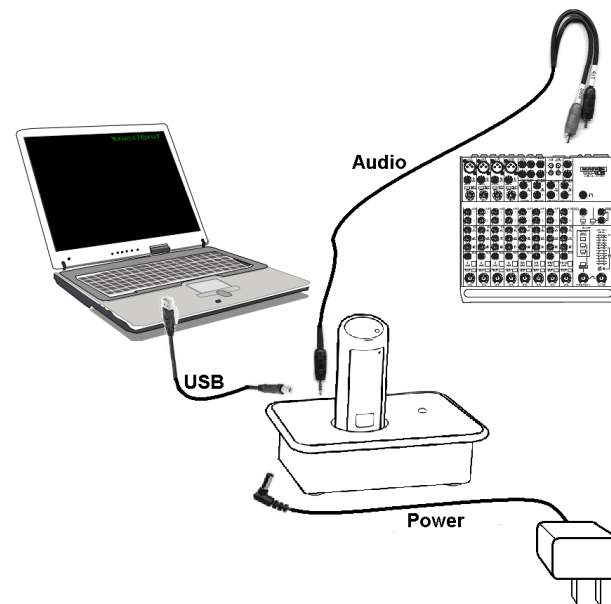

Computer Software Set-up

Use the supplied USB cable to connect the mini USB connector to the Charger Base and the standard end to your computer USB port. Your computer will alert you that it has found a new USB device.

It is possible to configure your computer settings to playback audio through the earpiece attached to the Wearable microphone (default settings) or through the computer speakers (internal or desktop).

The following examples use the Microsoft Windows® XP Operating System Classic settings. You may notice slight differences in appearance when using other Windows operating systems.

To modify the default microphone earpiece audio output settings:

1. At the lower-right of your screen, click the Start button.
2. Select *Settings* and *Control Panel*.
3. Click the *Sounds and Audio Devices* icon.

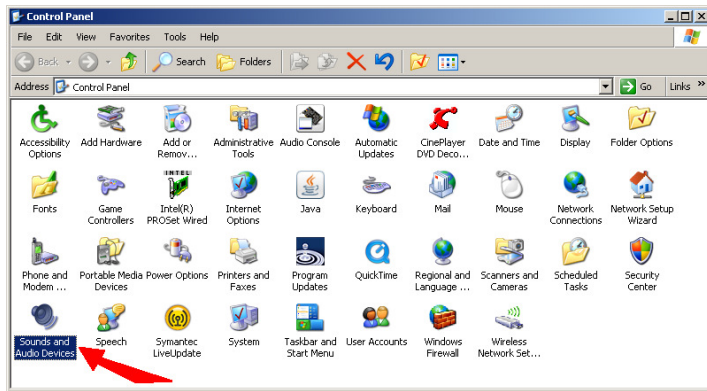

The Sounds and Audio Devices Properties dialog will display, as shown. The solo-Desktop device will be selected.

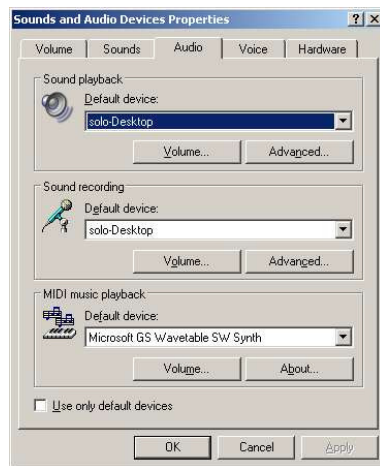

4. Open the *Volume* settings for *Sound recording* to view the volume levels selected for the microphone input (*Capture*) on the computer.

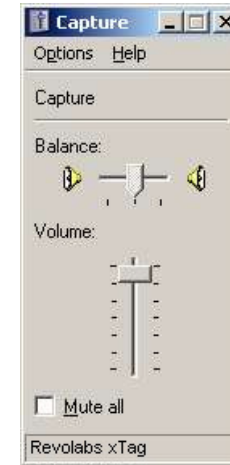

5. Make sure that the level for the Microphone is close to the top (maximum) and that the Mute box is not checked.
6. In the *Sound playback* section, open the Volume settings for to control the volume you hear in the Microphone's earpiece.

Adjust the *Speaker* level at the master Volume control if necessary.

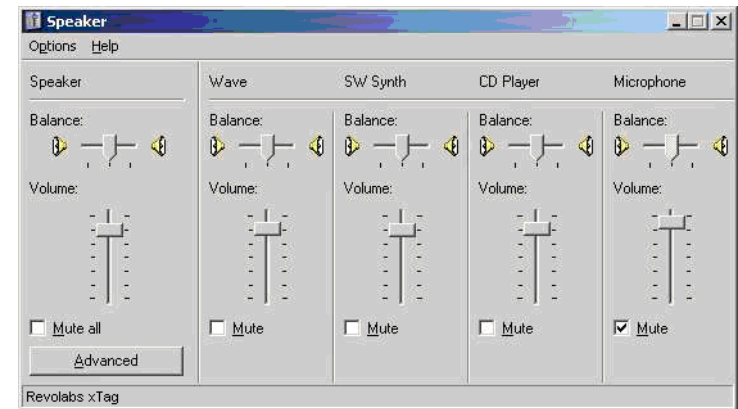

- At the bottom of the Microphone section, click the *Mute* box in the *Microphone* section to prevent the Microphone directly feeding back its own audio to the earpiece (i.e. “sidetone”).

It may be necessary to use the Options-Properties menu to display the *Microphone* volume control.

IP telephony and computer telephony applications (e.g., Skype) may also offer options for controlling the audio levels and playback capabilities. Please consult the application guide for the software package for additional instructions.

- Change the Sound playback Default device to your regular audio codec (SigmaTelAudio in this example) to playback audio through the internal or external speakers of the computer instead of the earpiece.
- At the bottom of the dialog, click *Apply*, and then click *OK*.

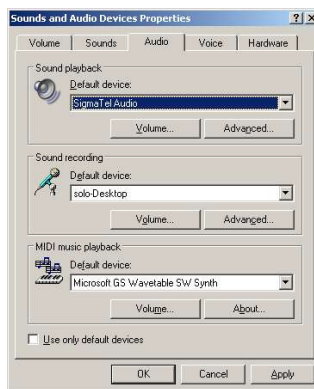

Note: Laptop computers with built-in microphones may continue to operate even when the solo-Desktop software is running. To prevent the built-in microphone audio feeding through to the speakers, check the Mute box on the laptop audio program Input Monitor, as shown below.

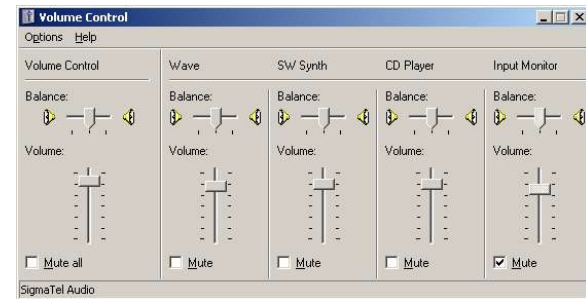

Revolabs Solo™ Wireless Microphones

Using with Wearable Wireless Microphone

The wireless personal microphone uses encrypted communication to synchronize with the Charger Base. It provides high quality full duplex audio between the user and the computer, audio or video conference system or external audio system. The system allows the wearer to step out of the office or conference room and still participate in the call.

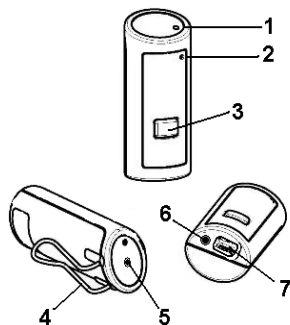

1. Microphone port — direct toward mouth for best audio pickup.
2. Noise cancelling port — do not block opening.
3. Mute Button — press to mute, un-mute and pair microphone.
4. Pocket clip — also used to attach microphone to lanyard.
5. LED display — visual status for mute, un-mute, and pairing.
6. Earpiece jack — accepts the 2.5mm plug for the earpiece.
7. Charging port — docks to Solo Charger Bases.

Note: *Microphones in new systems must be paired to the Charger Base. See microphone pairing instructions on page 18.*

Revolabs Solo™ Wearable Microphones turn on and mute automatically when removed from Charger Base, to reduce noise while being attached. The microphone has a clip on the back which allows the microphone to be easily attached onto a shirt pocket, blouse, lapel or lanyard.

To use the Wearable Microphone:

1. Remove the microphone from the Charger Base. The double-flashing RED LED on the Microphone and Charger Base confirm that the mic is paired and muted.
2. Attach the microphone to clothing or to a lanyard close to the mouth, within 6-12 inches (15–30cm) is recommended. Make sure microphone is attached securely with the microphone port pointed up toward mouth.
3. With the microphone in the wearing position, un-mute the microphone by pressing and releasing the Mute button (confirm by viewing flashing GREEN LED). If the volume is too low, move the microphone closer to the mouth.
4. To turn microphone off, return the Microphone to the Charger Base. The Microphone LED will show a 5 second self-test pattern and begin charging (solid RED or GREEN LED). Alternately, turn off the Microphone manually by pressing and holding the Mute button for 10 seconds, until the LED turns solid RED, then release the mute button and the LED will turn OFF.

If the microphone is moved out of range of the Charger Base (~65 feet or 20m) the connection will be dropped (LED flashes all colors) and the microphone will mute.

After 15 seconds the microphone will beep 5 times, and will continue beeping every 30 seconds to remind the user to return the microphone to the conference room. If the microphone is moved back into range within 15 minutes the connection will automatically be re-established to its original state, and the beeping will cease. If not, the microphone will turn off.

Adjusting the Volume on the Wearable Microphone Earpiece

To change the volume on the Wearable microphone earpiece, use the dial on the earpiece wire.

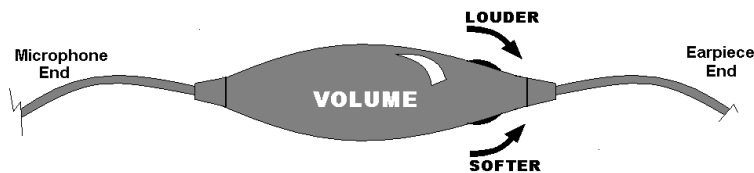

Turning the dial towards the earpiece, as shown in the figure, will increase the volume, and turning the dial towards the microphone will decrease the volume. Use the attached clothing clip to secure the earpiece wire.

Using with TableTop Microphone

The Revolabs Solo™ TableTop Wireless Boundary Microphones enable multiple phone conference participants to use a single microphone. Units are placed strategically on the conference table to ensure that all participants can be heard clearly.

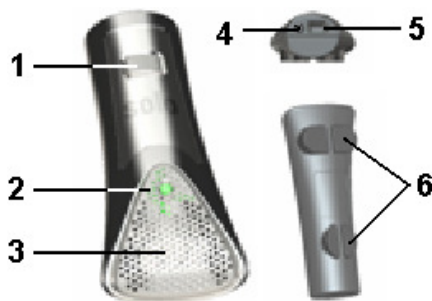

1. Mute Button — press to mute, un-mute and pair microphone.
2. LED display — visual status for mute, un-mute, and pairing.
3. Integral grille — protects internal parts (non-removable).
4. Audio jack — accepts a 2.5mm plug for a powered speaker.
5. Charging port — docks to all Solo Charger Bases.
6. Rubber feet — non-slip, vibration absorbing pads.

To use the Wireless TableTop Microphone:

1. Remove the microphone from the Charger Base. The microphone turns on and mutes automatically when removed from Charger Base (flashing RED

LED), to reduce noise while placing the microphone on the table.

2. TableTop microphones should be centered on the table with the integral grill pointed toward the users (uni-directional), or centrally located between users (omni-directional), from 2 to 5 feet (.75 to 1.75m) away. It is always better to be as close to the person speaking as possible, but avoid placing the microphone where it might be blocked by equipment or meeting paperwork. Also do not place microphones too close to an audio or video conference speaker to avoid echoes.
3. With the microphone in position, un-mute the microphone by pressing and releasing the MUTE button (confirm by viewing flashing GREEN LED).
4. To turn microphones off, return the microphone unit to the Charger Base. The Microphone LED will show a 5 second self-test pattern and begins charging (solid RED or GREEN LED). Alternately, press and hold the MUTE button for 10 seconds until the LED turns solid RED, then release the mute button and the LED will turn OFF.

If the microphone is moved out of range of the Charger Base (~65 feet or 20m) the connection will be dropped (LED flashes all colors) and the microphone will mute.

After 15 seconds the microphone will beep 5 times, and will continue beeping every 30 seconds to remind the user to return the microphone to the conference room. If the microphone is moved back into range within 15 minutes the connection will automatically be re-established to its original state, and the beeping will cease. If not, the microphone will turn off.

Using with XLR Microphone Wireless Adapter

The Revolabs Solo™ Universal Wireless Adapter for Handheld Microphones, shown in the following figure, is connected to your existing handheld dynamic

microphones for wireless freedom during open mic meetings, Q&A sessions, classrooms, etc.

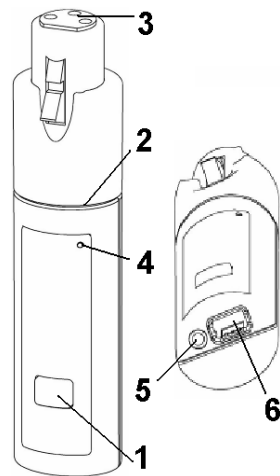

- 7. 1. Mute button — press to mute, un-mute and pair microphone.
- 8. 2. Rubber collar — durable and impact/strain protection.
- 9. 3. XLR Female connector — balanced audio for dynamic microphones.
- 10. 4. LED display — visual status for mute, un-mute, and pairing.
- 11. 5. Audio Out port — accepts the 2.5mm plug for the earpiece.
- 6. 6. Power/Charging Port — docks to all Solo Charger Bases.

To use the Revolabs Solo™ Universal Wireless Adapter:

5. Remove the Microphone Adapter from the Charger Base.

The adapter turns on and mutes automatically when removed from Charger Base (flashing RED LED). The XLR Microphone Adapter is attached to a standard dynamic microphone to convert it from a wired microphone to a wireless microphone (see following figure).

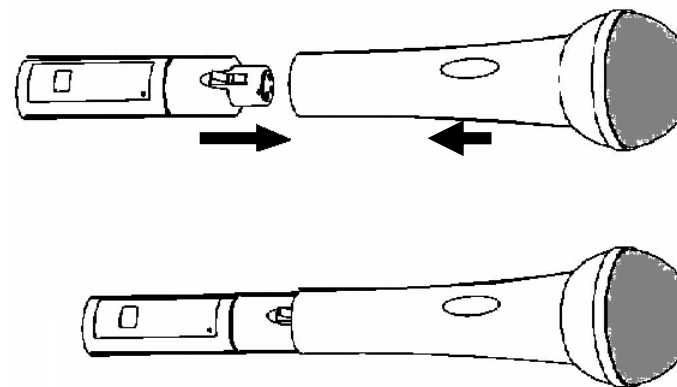

The Adapter does not provide phantom power or bias current so it cannot be used with condenser or electret microphones.

6. With the microphone attached, un-mute the Adapter by pressing and releasing the Mute button (confirm by viewing flashing GREEN LED).

Note: *If the microphone has an on-board mute switch, this switch must also be un-muted prior to use.*

7. To turn the Adapter off, return the microphone unit to the Charger Base or press and hold the Mute button for ~10 seconds until the LED turns solid RED and release button.

Important: Always remove the microphone from the Adapter by pressing the latch switch and separating the parts before returning the Adapter to the Charger Base.

If the microphone is moved out of range of the Charger Base (~65 feet or 20m) the connection will be dropped (LED flashes all colors) and the microphone will mute.

After 15 seconds the microphone will beep 5 times, and will continue beeping every 30 seconds to remind the user to return the microphone to the conference room. If the microphone is moved back into range within 15 minutes the connection will automatically

be re-established to its original state, and the beeping will cease. If not, the microphone will turn off.

Using with a Solo Executive Multi-channel System

The Revolabs Solo™ Single Channel Wearable Microphone can be paired to a Solo Executive Multi-channel Wireless Microphone System for users who wish to have a single microphone to use in both the office and in the conference room. This is accomplished by pairing the Single Channel Wearable Microphone to the Executive Multi-channel Base Station and docking the Microphone in the Executive Charger Base. The Microphone can then be used in either system by placing the Microphone in the respective Charger Base for about 5 seconds.

Charging the Batteries

To charge the batteries place the Microphone into the Single Channel Charger Base. During charging, the Microphone status LED indicator changes from solid RED to solid GREEN as charging completes. The Charger Base status indicator remains off during charging. The Microphone is always muted while in the Charger Base. The battery charges from fully depleted to fully charged in approximately two hours, however, it is “quick-charged” to 80% capacity in 45 minutes.

Note: *A fully charged battery provides approximately 8 hours of talk time.*

When to Charge

Before using the Microphone for the first time, charge for 8 hours or overnight in the Charger Base (until microphone LED turns solid GREEN).

When the Microphone LED begins flashing alternating YELLOW and RED or YELLOW and GREEN, the battery needs recharging. Over time (years), batteries gradually wear down and require charging after a shorter period of use. This is normal.

Important: The Lithium Polymer rechargeable battery that powers the Microphone is not user serviceable. Please see the Revolabs website (www.revolabs.com) for information regarding battery replacement and proper disposal procedures. **Warning: Exposing the batteries to fire may result in an explosion.**

Setting the Broadcast Power Level

In confined settings where multiple Solo Executive Single Channel systems are used, or where audio interference is likely, it may be necessary to reduce the broadcast power levels.

The broadcast power level between the Microphone and Charger Base can be set to the following three levels.

- Highest power level – 60 feet (25M) maximum operating distance between Microphone and Charger Base (default setting).
- Medium power level – 20 feet (7M) maximum operating distance between Microphone and Charger Base.
- Lowest power level – 6 feet (2M) maximum operating distance between Microphone and Charger Base.

To set the broadcast power level:

Press and hold the Mute button while plugging the USB cable into the Charger Base.

The status LED on the Charger Base will display a sequence of flashes, during which it will flash once, then twice, then three times, where:

- 1 GREEN flash = full power
- 2 GREEN flashes = medium power
- 3 GREEN flashes = low power.

This cycle will repeat 10 times. During any of the cycles, simply release the Mute button immediately after the desired power indication, to set the

Executive Single Channel system broadcast/receive power.

Pairing the Microphone to the Charger Base

“Pairing” creates an encrypted association between the Wireless Microphone and the Charger Base with a unique electronic serial number. When the Microphone and Charger Base have been previously paired, the Microphone will automatically try to connect to the Charger Base whenever it is lifted from the Charger Base.

Note: *The Microphone in new systems will need to be manually “paired” prior to first use.*

If a Microphone is lifted from the Charger Base and the Microphone LED slowly flashes alternating RED and GREEN for 10 seconds, it means that the Microphone needs to be paired to the system.

To pair the Microphone to the Charger Base:

1. Make sure the Microphone is turned OFF (no LED activity). If the unit is ON, press and hold the MUTE button for 10 seconds until the LED turns solid RED then release. Alternately, place the Microphone in the Charger Base for less than 2 seconds.
2. Enable the pairing mode by holding the Microphone’s Mute button down for eight seconds.

The LED will turn solid GREEN and then solid RED. Release the Mute button. The Microphone unit is now in *pairing* mode.
3. Push and hold the Charger Base’s Mute button for eight seconds to enter into pairing mode then release.
4. The LED will be solid RED until pairing is complete, as indicated by double flashing RED on both the Microphone and the Charger Base (paired and muted audio). If pairing fails at the end of one minute on either unit, the LED will flash

alternately GREEN and RED for a few seconds and turn OFF. If this happens, repeat these steps.

LED Status Indications

The following LED patterns are shown on either the Microphone or the Charger Base.

| LED Pattern | Meaning |
|--|--|
| Solid GREEN (Microphone only*) | Confirmation of power-up or battery reaching full charge. * In earlier versions LED will turn OFF when fully charged. |
| Solid RED | Pairing mode, or confirmation of powering-down, or battery charging. |
| GREEN flash every 1.5 seconds | Microphone paired, connected and unmuted. |
| Two RED flashes every 1.5 seconds | Microphone paired, connected and muted. |
| YELLOW flash alternating with GREEN flash | Microphone paired, connected, un-muted and battery low. |
| YELLOW flash alternating with two RED flashes | Microphone paired, connected, muted and battery low. |
| Alternating RED, YELLOW, GREEN, YELLOW (Microphone only) | Searching for a connection, or out of radio range. The Microphone will try to re-establish the link for about 15 minutes, and then turn off automatically. The Microphone will beep five times every 30 seconds. |
| Alternating slow RED and GREEN | Microphone is not paired to Base Station. |
| Rapid RED flashes continuing for more than a few seconds | Radio congestion – it is not possible to make a radio connection because there are already too many nearby users, or there is heavy radio interference. Interference may be caused by some types of digital cordless phones, and other Revolabs Solo™ installations. |
| Groups of five rapid red flashes | Unit is faulty. Please contact your place of purchase for advice on return. |

Warranty

Revolabs, Inc. warrants this product to be free of manufacturing defects. Repair or replacement of any defective part or unit (at the discretion of the Seller) will be free of charge for the period of 90 days.

Any attempt by the user to alter the equipment, or equipment damaged by negligence, accident, or Acts of God voids this warranty.

The Seller shall not be liable for any consequential damage resulting from the malfunction of this product. Should the user experience unsatisfactory performance from this equipment, contact the Seller to obtain instructions for return, or replacement, as deemed necessary.

This warranty is not transferable by the original end user.

Revolabs, Inc.
63 Great Road
Maynard, MA 01754
www.revolabs.com
1-800-326-1088

Solo Single Channel Specifications

Dimensions, (L, W, H) and Weight

Single Channel Charger Base

3.9" (10 cm) x 2.4" (6 cm) x 1.0" (2.56 cm), 0.5 lb (0.23 kg)

Wearable Microphone:

0.9" (2.3 cm) x 0.8" (2.0 cm) x 2.6" (6.6 cm), 0.05 lb (0.02 kg)

TableTop Microphone:

1.5" (3.8 cm) x 0.8" (2.0 cm) x 3.3" (8.4 cm), 0.05 lb (0.02 kg)

XLR Adapter:

0.9" (2.3 cm) x 0.8" (2.0 cm) x 4.0" (10.2 cm), 0.05 lb (0.02 kg)

Shipping Weight

1.5 lbs (0.68 kg)

Radio Frequency

02-DSKSYS - 1.92 to 1.93 GHz (UPCS North America)

04-DSKSYSEU - 1.88 to 1.90 GHz (DECT EU)

Connectors

Single Channel Charger Base

Power – 5VDC, proprietary 0.7mm connector

Mini USB – 5 pin connector, USB 2.0

Audio unbalanced In/Out – 2.5mm

Tip: Audio Out (line level, 0dBV)

Ring: Audio In (line level, 0dBV)

Shield: GND

Wireless Microphone

Power – proprietary 4 pin connector

Audio – 2.5mm mono audio

Microphone patterns Executive unidirectional – cardioid.

TableTop omni-directional and uni-directional available.

Power Requirements

Power Adapter 110 - 240VAC, 50-60Hz to 5VDC, 300mA

Battery Lithium Polymer, up to 8 hours talk time

Charge Time 2.0 hours approx.

Range 65' (20 meters) approx. (no obstructions)

Audio Bandwidth 100-7000 Hz

Encryption 128-bit DSAA (DECT Standard Authentication Algorithm) authentication, 64 bit DECT Standard Cipher

Environmental Requirements

Temperature 40° to 105° F (5° to 40° C) operating

Humidity 20% to 85%

Note: *Microphones must be fully charged and paired to the Charger Base prior to first use.*



Revolabs Solo™ Single Channel
02-DSKMAN-PAP-11
December 2007 (Rev 3.1)